

R1 to R4 are needed only when channels could be used individually.

No hardware handshake, see the "full" version. A dummy (fake) handshake was implemented. Channel A and B may be used individually. P1 and P2 may be a female 0.1" header, allowing direct connection to Milk. P1 and P2 may be just pads to solder a ribbon cable.

Rx/Tx LEDs

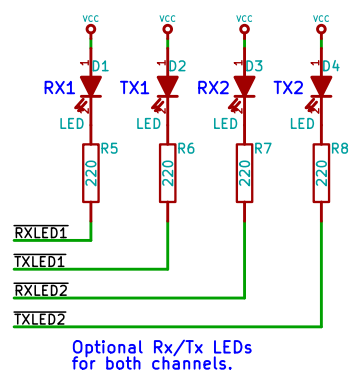

Optional Rx/Tx LEDs for both channels.

MILK

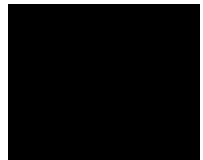

Author: Salvador E. Tropea
 \$Revision: 1.3 \$
 INTI - CMNB

File: RS232_DB9_basic_buffered.sch
 Sheet: /

Title: Dual RS-232 basic cable (null modem)

Size: A4 Date: 6 jul 2015

KiCad E.D.A.

Rev: Ver arriba

Id: 1/1